

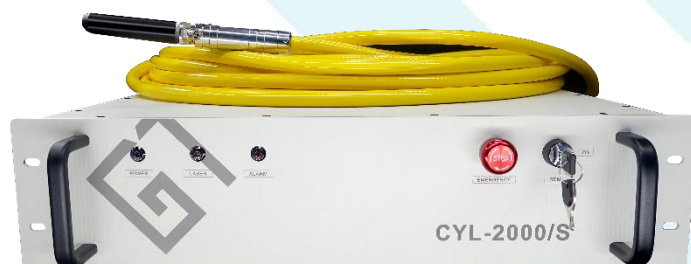

CYL-2000/S

1.0 μ m Single Mode
Continuous Fiber Laser
User manual



ZHEJIANG GT LASERS TECH.CO., LTD.

Before using this product, please read the user manual carefully. Please put the product specification together with the product to provide you with relevant important information at any time.

Attention

We reserve the right to modify the information in this manual without prior notice. GT Lasers believes that the information provided in this manual is accurate and reliable, but GT Lasers does not undertake any warranty regarding the contents of this manual, including but not limited to the implied warranties of merchantability and applicability. Moreover, GT Lasers will not be liable for any patent infringement or damage to the rights and interests of any third party caused by the use of this manual. GT Lasers will not be responsible for any error information in this manual. GT Lasers is not liable for any accidental or indirect consequences arising from the provision, execution, or use of this manual.

Direct or indirect use of the information provided in this manual does not mean that GT Lasers authorizes any patent or other intellectual property.

Zhejiang GT Lasers Tech. Co., Ltd. All rights reserved. This content is not allowed to be reproduced, transmitted, stored, or adapted for publication in any form or method without the written authorization of GT Lasers, unless permitted by the relevant copyright law.

Contents

1.0 Safety Information	4
1.1 Security identity	4
1.2 Laser safety level	5
1.3 Optical security	5
1.4 Electrical security.....	5
1.5 Other safety precautions	5
2.0 Description of Product	5
2.1 Product characteristics	5
2.2 Product advantage.....	6
2.3 Main applications.....	6
2.4 Specification	6
2.5 Order information	7
3.0 Product Installation.....	8
3.1 Actual configuration list.....	8
3.2 Unpacking and inspection.....	8
3.3 Operating environment	8
3.4 Product performance.....	9
3.5 Notes	10
3.6 Installation dimensions	10
3.7 Installation notes	10
3.8 Precautions for the cooling system	11
4.0 Use of Products	12
4.1 Front panel of the product.....	12
4.2 Rear panel of the product.....	13
4.3 Control interface definition.....	错误!未定义书签。
4.4 Power connection.....	15
4.5 Start operating procedures	17
4.6 Control Mode Selection	17
4.6.1 External control mode (daily use status).....	17
4.6.2 Internal control mode (for debugging only).....	17
5.0 Quality Assurance and Repair and Return Process	18
5.1 General warranty.....	20
5.2 Services and maintenance	20
5.3 Change	20

1.0 Safety Information

Thank you for choosing GT Lasers fiber laser, this user manual provides you with important safety, operation, maintenance, and other information. Therefore, please read this user manual carefully before using this product.

We will use different words and characters to alert you to potential hazards and important information, including:

1.1 Security identity

	<p>WARNING</p> <p>May cause serious personal injury or even endanger life.</p>
---	---

	<p>CAUTION</p> <p>May cause general personal injury or damage to products or equipment.</p>
---	--

	<p>IMPORTANT</p> <p>This symbol represents laser radiation and this symbol appears on products with laser output.</p>
---	--

Safety Guidance

To ensure safe operation and optimize the performance of this product, please strictly abide by the following WARNINGS and CAUTIONS, and other information contained in this manual.

WARNING: when using this product, please make sure to use the appropriate grounding power.

WARNING: the user is not allowed to open any part inside the product for maintenance. If necessary, please contact GT Lasers technicians to provide maintenance services. Any unauthorized changes to this product will result in the warranty invalidation.

WARNING: the output connector of this product is connected by fiber optic cable and laser. Please use the output connector carefully.

WARNING: if this product is not operated in accordance with the instructions. The protection mechanism provided by this product may be affected. This product must be and can only be used under normal conditions.

CAUTION: when operating the fiber output connector (such as installing the connector, testing the connector end face with an optical instrument), be sure to keep the AC power off.

1.2 Laser safety level

According to European standard EN 60825-1, clause 9, this series of lasers belong to 4 types of laser instruments. The product emits laser radiation with a wavelength of 1080nm or around 1080nm, and the optical power radiated from the output head is greater than 100W~3000W (depending on the model). Direct or indirect exposure to such light intensity can cause damage to the eyes or skin. Although the radiation is invisible, the laser beam can cause irreparable damage to the retina or cornea. Suitable and certified laser protective glasses must be worn throughout the operation of the laser.

WARNING: laser safety protective glasses should be worn throughout the operation of the product. Laser safety protective glasses have laser wavelength protection selectivity, so please choose the laser safety protective glasses that accord with the laser output band of the product. Even if you wear laser safety glasses, it is forbidden to watch the output head directly when the laser is electrified, whether or not it is in the state of light.

1.3 Optical security

If there is dust on the lens of the laser output head, the crystal of the laser output head will be damaged or the laser will cause irreparable damage.

CAUTION: do not output the laser without the laser output head protection cap removed, otherwise the laser output lens or crystal will burn down.

1.4 Electrical security

Ensure the product ground wire is effectively grounded and the environment is safe and reliable.

WARNING: product grounding disconnect will cause the laser shell to be electrified, which may cause personal injury to the operator.

Ensure the AC voltage supply is normal.

CAUTION: the wrong wiring or supply voltage will cause irreparable damage to the laser.

1.5 Other safety precautions

Do not look directly at the laser output head while the laser is running.

Do not use fiber laser in dark.

Please strictly follow the laser manual to operate the laser, otherwise any damage to the laser will not be guaranteed.

The laser does not have built-in usable accessories, all repairs should be carried out by GT Lasers technicians. To prevent electric shock, please do not damage the label or remove the lid, otherwise any damage to the laser will not be guaranteed.

2.0 Description of Product

2.1 Product characteristics

GT Lasers CYL-1000/S, CYL-1500/S, CYL-2000/S, CYL-3000/S single-mode 1.0 μ m

continuous fiber laser uses the latest technology and optimum design. It has the advantages of high electro-optical conversion efficiency, long service life, high safety, and reliability. With good output beam quality and strong anti-high reflective ability, which can be widely used in laser cutting, welding, drilling, 3D printing and other fields.

GT Lasers has established a scientific after-sales service system with Internet technology. Each equipment has a unique identity code (that stores the original technology and material information of the machine), which can be used for remote real-time monitoring online, providing users with fault warning, quick technical support and after-sales service.

GT Lasers with its high quality, high reliability and excellent cost performance, can meet the diverse needs of customers, customization and good after-sales service, which is an ideal choice for system integrators and equipment manufacturers.

2.2 Product advantage

High electro-optic conversion efficiency greatly reduces power consumption cost

Strong anti-high reflective ability, suitable for processing different materials

Remote real-time monitoring

Long service life, high safety and reliability

Personalized customization

Good after-sales service system

Excellent performance-to-price ratio

2.3 Main applications

Laser cutting, laser welding, laser cladding, laser brazing, laser surface heat treatment, etc.

2.4 Specification

Performance		Min.	Typ.	Max.	Remarks		
Optical characteristics	Central wavelength	(nm)	1070	1080	1090		
	Spectral bandwidth	(nm)		3	5	-3dB	
	Output optical power	CYL-1000/S	(W)		1000		
		CYL-1500/S			1500		
		CYL-2000/S			2000		
		CYL-3000/S			3000		
	Short time power stability	(%)	±1				
	Long time power stability	(%)	±2				
	Laser opening time	(μs)	50~100				
	Laser shutdown time	(μs)	100~200				
	Power regulation range	(%)	10		100		
	Beam quality	(M ²)			1.3	QBH-20/400	
					2.8	QBH-50/360	
Modulation frequency	(KHz)	5		20	100% output		
Red light Power	(mW)	5		60			
Output characteristics	Output connector			QBH	Customizable		
	Output fiber core diameter	(μm)		20	100		
	Output fiber length	(m)		15		Customizable	
	Output cable bending radius	(mm)	200				

	Work model		Continuous/modulation			CW/Modulate	
	State of polarization		Random			Random	
Electrical cooling characteristics	Communication interface		RS232/AD /Super terminal				
	Remote communication		APP			Customizable	
	Power supply	(V)		220			
	Power consumption	CYL-1000/S	(KW)			3.0	Single phase three
		CYL-1500/S				4.5	
		CYL-2000/S				6.0	220 V in two groups
		CYL-3000/S				8.5	
	Cooling mode		Water cooling			External	
	Cooling water temperature	(°C)	20		28		
	Cooling water flow	CYL-1000/S	(L/min)		10		
CYL-1500/S				20			
CYL-2000/S				25			
CYL-3000/S				40			
General characteristics	Working ambient temperature	(°C)	10		40		
	Working environment humidity	(%)	10		85		
	Storage temperature	(°C)	-10		60		
	Structure		Rack				
	Weight/ Size	CYL-1000/S	(kg)	38	(W)×(L) with Handle)×(H) (mm)	482.6(440)×451×104	
		CYL-1500/S		40		482.6(440)×451×104	
CYL-2000/S		43.4		482.6(440)×596×111			
CYL-3000/S		53		482.6(440)×666×111			

2.5 Order information

C	Y	L	-	□	□	□	□	/	S	-	Q	B	H	-	□	□	□	/	□	□		
C	CW	Y	YDF 1.0μm	Fiber laser	Output power		Mode		Output connector		Output fiber core diameter		Fiber length									
					500	500W	S	Single	QBH	QBH	20	20/400	15	15m								
Q	QCW	E	EDF EYDF 1.5μm		1000	1000W	M	Multi	LOC	LOC	25	25/400	20	20m								
P	PULSE				1500	1500W	H	Anti-high reflection	QCS	QCS	50	50/360	XX	Custom izable								
					2000	2000W							100	100/360								
					3000	3000W							150	150/360								

3.0 Product Installation

3.1 Actual configuration list

Please refer to the packing list in the packing box.

3.2 Unpacking and inspection

Through specially designed packaging materials and boxes, GT Lasers ensures that the laser can always be fully protected during transportation. Nevertheless, to prevent the unpredictable situation in the transportation process, the user still needs to carefully check whether the packing box is placed correctly and whether there is any damage such as collision, cracking and flooding outside the box before opening the box. Once the external box is found to be abnormal, please inform GT Lasers in time so that we can deal with it as soon as possible.

After unpacking, please check whether the packing list is consistent with the actual items. If in doubt, please contact GT Lasers in time.

When the laser is taken out of the box, attention should be paid to avoid the collision or violent vibration to the laser. When taking out the coiled laser output cable, we should pay special attention to it, do not twist, bend, pull the laser output cable, and avoid the collision and vibration of the laser output head.

CAUTION: laser output cable is a precise optical device, twisting or overbending the output cable, vibration and impact of the laser output head will cause irreparable damage to the laser.

3.3 Operating environment

Supply voltage (V)	AC 220V±10%, 50/60Hz
Power supply capacity (KW)	Less than 7.5
Environment of placement	Smooth without shock or impact
Operating ambient temperature (°C)	10~40
Operating ambient humidity (%)	30-70

- 1) Ensure reliable grounding before using the laser.
- 2) The laser output head is connected to the output optical cable. Please check the laser output head carefully to prevent dust or other pollution. Please use special lens paper when cleaning the laser output head.
- 3) If the laser is not used as specified in this manual, the laser may be in an abnormal working state and cause damage.
- 4) It is forbidden to install the laser output head when the laser is in operation.
- 5) Do not directly watch the laser output head, and be sure to wear laser protective glasses while operating the laser. The best reliability and performance will be acquired when the laser is installed in an air-conditioned environment.

CAUTION: do not expose this product to a high humidity environment (humidity >95%). Do not let this product work below the dew point temperature. (As Table below)

Constant dew point table at ambient temperature and relative humidity									
Ambient temperature °C	Maximum relative humidity								
	20%	30%	40%	50%	60%	70%	80%	90%	95%
20	-3.5	2	6	9	12	14.5	16.5	18	19
25	0.5	6	10.5	14	16.5	19	21	23	24
30	4.6	10.5	15	18.5	21.5	24	26	28	29
35	8.5	15	19.5	23	26	28.5	31	33	34
40	13	20	24	27.5	31	33.5	36	38	39
Laser operating temperature range									

CAUTION: in actual use, the ambient temperature exceeds 30°C. In order to effectively prevent condensation, clean dry air should be injected into the one-way air inlet valve at the back of the chassis, and the air pressure should be kept at 0.1Mpa.

3.4 Product performance

The technical parameters of the laser are as follows:

Optical characteristics	
Output power (W)	2000
Working mode	Continuous or pulsed
Polarization direction	Randomized
Central wavelength (nm)	1080
Optical output characteristics of QBH output heads	
Numerical aperture (NA)	0.22
Fiber Core Diameter (μm)	50
Output fiber length (m)	15
Electrical characteristics	
Working voltage	AC 220V±10%, 50, 60HZ
Other characteristics	
°C Size (W×L ×H)(mm)	482.6(440)×451×111
Operating ambient temperature range (°C)	10~40
Operating ambient humidity range (%)	30~70
Storage temperature (°C)	-10~60
Cooling mode	Water cooling

3.5 Notes

- 1) Before connecting the laser to the AC power supply, ensure that it is connected to **220V AC** voltage, wrong connection to the power supply will cause irreparable damage to the laser.
- 2) It is very important to ensure that the output end of the adjusted laser output head is clean, otherwise the laser will be irreparably damaged.
- 3) When the laser is not used, please cover the output head protective cap, do not touch the lens at the output end. If necessary, use special lens paper and alcohol to clean the lens.
- 4) The loss of optical power may be caused by incorrect operation by the above specifications, such loss will not be covered by warranty.

3.6 Installation dimensions

Figure 1 Laser dimensions (unit: mm)

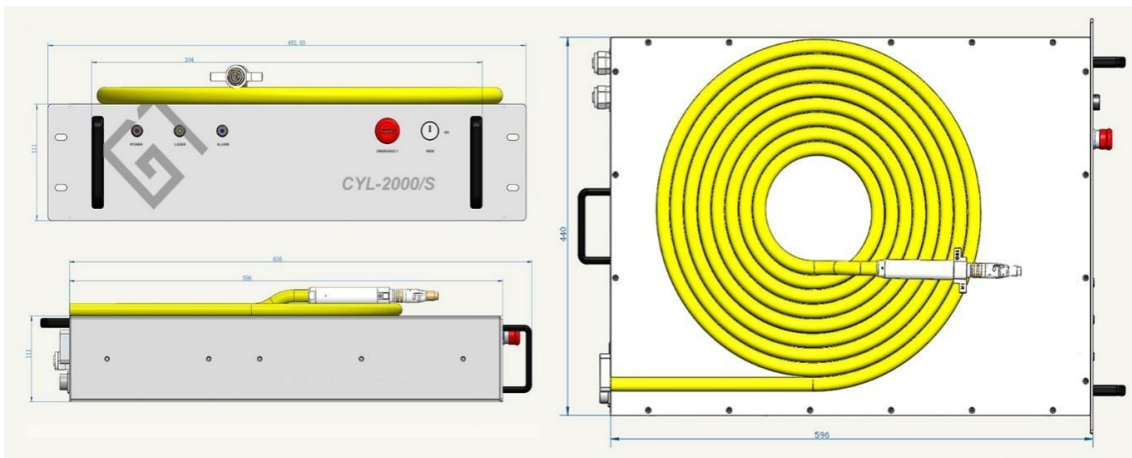
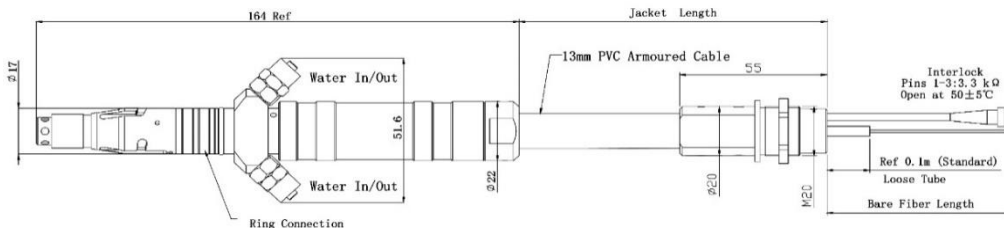

Figure 2 QBH Output head (unit: mm)



Before the laser works, the two copper contacts (Interlock pins) on the output head must be short connected, otherwise the laser cannot work normally.

3.7 Installation notes

- 1) Placing the laser horizontally in an appropriate position and fixing it as necessary.
- 2) Please check whether the AC power supply of the laser is at the appropriate voltage (**2 sets 220V AC±10%, 50/60Hz**) and whether the grounding wire is good before the laser is powered on.
- 3) Connect the power line to the control cable of the laser in the uncharged state.
- 4) Connect the cooling system to the laser and the output head according to the the water inlet and outlet mark.
- 5) Please check the output head of the laser, make sure it is clean and then install it on the equipment.
- 6) Do not step on, squeeze or overbend the protective tube during the installation of the jumper wire to avoid damage to the optical fiber.
- 7) In the process of installing the jumper output head, the surrounding environment should be kept clean (do not use an electric fan to dissipate heat in summer to avoid heavy dust in the air).

- 8) The minimum bending diameter of the transmission fiber of the laser should not be less than 20cm in the non-working state such as transportation and storage; the minimum bending diameter should not be less than 30cm in the laser emitting state.

CAUTION: all control lines of the lasers should be connected in a non-electric state, and the live installation of control lines may cause laser damage.

CAUTION: (1) if the winding diameter of the output cable is too small, the laser will be damaged. (2) The lens and cutting head cavity must be clean before assembling the laser output cable. (3) Please take good care of the output head protective cap to prevent it from being polluted. Otherwise, it will cause indirect pollution to the output head when the cap is covered.

3.8 Precautions for the cooling system

Parameters	Unit	2000W
Refrigerating capacity	KW	≥5
Min. flow	L/min	25
Max. output pressure	Bar	7
Water pipe size	mm	hosepipeφ16

Water temperature setting for the cooling system: $24\pm 1^{\circ}\text{C}$;

Cooling system requirements:

- 1) Purified water is used for cooling water. It is recommended to use purified drinking water.
- 2) To prevent mold growth in the chiller from clogging the pipe, it is recommended to add ethanol when filling the purified water. The amount of ethanol should be 10% of the purified water.
- 3) When the ambient temperature of the equipment is $-10^{\circ}\text{C}\sim 0^{\circ}\text{C}$, ethanol solution with a volume ratio of 30% must be used and replaced every two months.
- 4) When the ambient temperature of the equipment is below -10°C , a dual-function chiller must be used and the cooling system must be kept in continuous operation.

Other requirements for cooling system:

- (1) When starting the cooling system for the first time, the leakage of water throughout the waterway system and joints shall be checked. The external water pipe must be installed and connected according to the inlet (IN) and outlet (OUT) identified by the laser, otherwise the laser may not work properly.
- (2) If the laser is not used for a long time, the cooling water inside the cooling system and the laser should be emptied, otherwise it will cause irreparable damage to the laser.
- (3) When emptying the cooling water of the laser water cooling system, customers should use compressed gas with pressure less than 0.5 MPa, otherwise it will cause irreparable damage to the water cooling system.

Water cooling requirements for output cables:

Cooling water flow: 1.7-2.0L/min

Water cooling pressure: inlet less than 0.6Mpa

Water pipe type: outer diameter $\phi 6$ inner diameter $\phi 4$

Cooling water direction: unidirectional, connect the water pipe in strict accordance with the water inlet and outlet direction marked on the shell.

Cooling water quality: deionized water, distilled water, purified water

Cooling water PH range: 5.5-9

A water cooler shall be equipped with a filter element with a filter particle size of less than 100 um.

Max. cooling water temperature: 40°C

Min. cooling water temperature: 5°C higher than saturated dew point temperature

Additives in cooling water: meet the above requirements of PH values and solid particle size

Long-term vibration, less than 2G; impact, less than 10G.

CAUTION: correctly set the water temperature of the cooling system according to the ambient temperature. Setting the water temperature too high will lead to the laser cannot work properly, setting the water temperature too low will lead to condensed water to be generated inside the laser or in the laser output cable, which will cause irreparable damage to the laser.

CAUTION: before turn on the laser, please ensure the cooling system work normally and the water temperature reaches a suitable temperature.

4.0 Use of Products

4.1 Front panel of the product



REM/ON: key switch, insert key and rotate to "ON" or "REM" position, the laser will enter external control or internal control mode.

POWER: power indicator light, blue light indicates that the power is on.

LASER: laser indicator light, yellow light indicates that the laser is working.

ALARM: alarm indicator light, red light indicates the machine failure.

EMERGENCY: emergency stop switch, press it to turn off the laser immediately and rotate clockwise to release the button. Use the key switch to power on the laser to back to normal.

4.2 Rear panel of the product

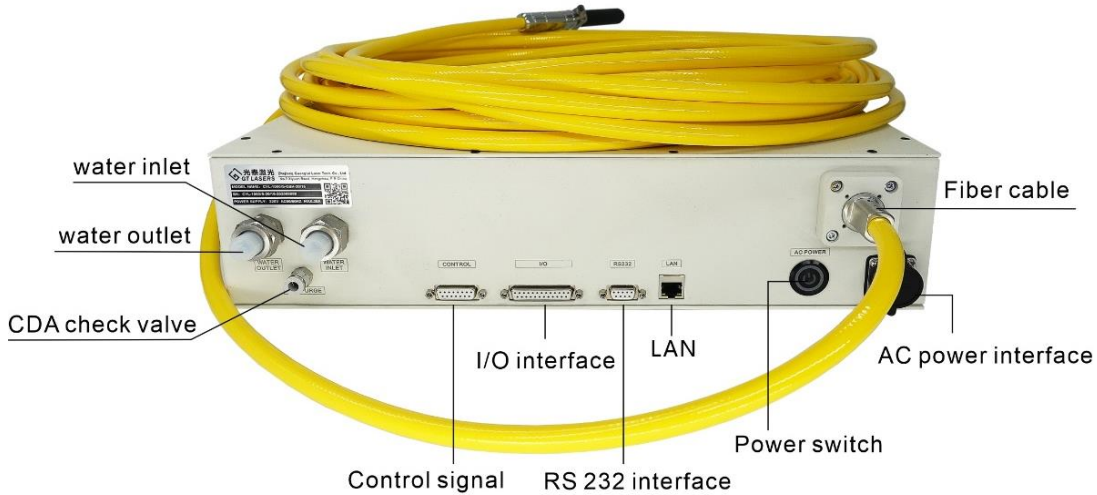

AC INPUT: AC power input socket, must be used with the plug provided by GT Lasers. This socket has a lock.

SERVICE: these service connectors provide **control signals (DB15 connector)**, **I/O (DB25 connector)**, **RS232 communications**, **LAN**, users can set control modes, input analog voltage signals, modulate 24V signals, and are also alarm signal output connectors.

RS-232 Serial Port Introduction

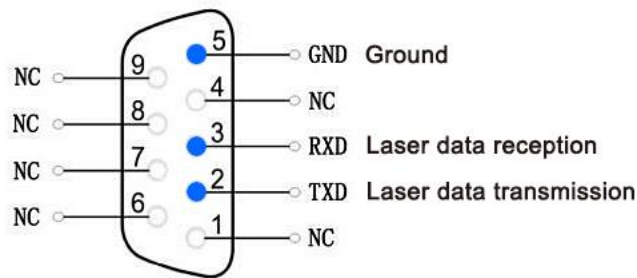

Each pin is defined as follows:

Pin NO.	Definition
2	TX
3	RX
5	GND
Other	Idle

4.3 Control interface definition

DB15 Control Interface Diagram

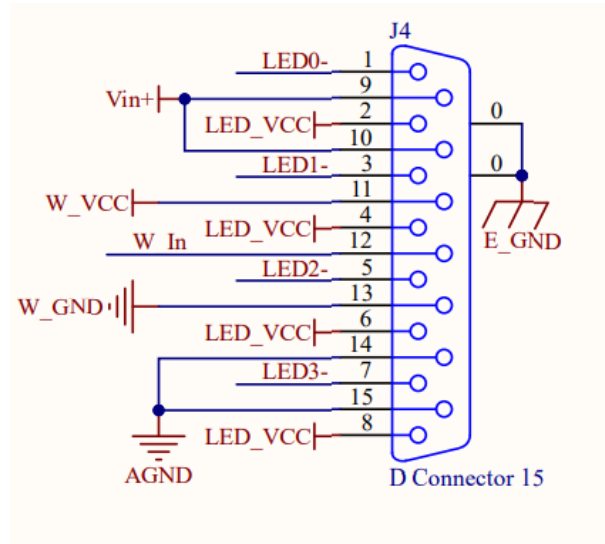

DB25 pin is defined as follows:

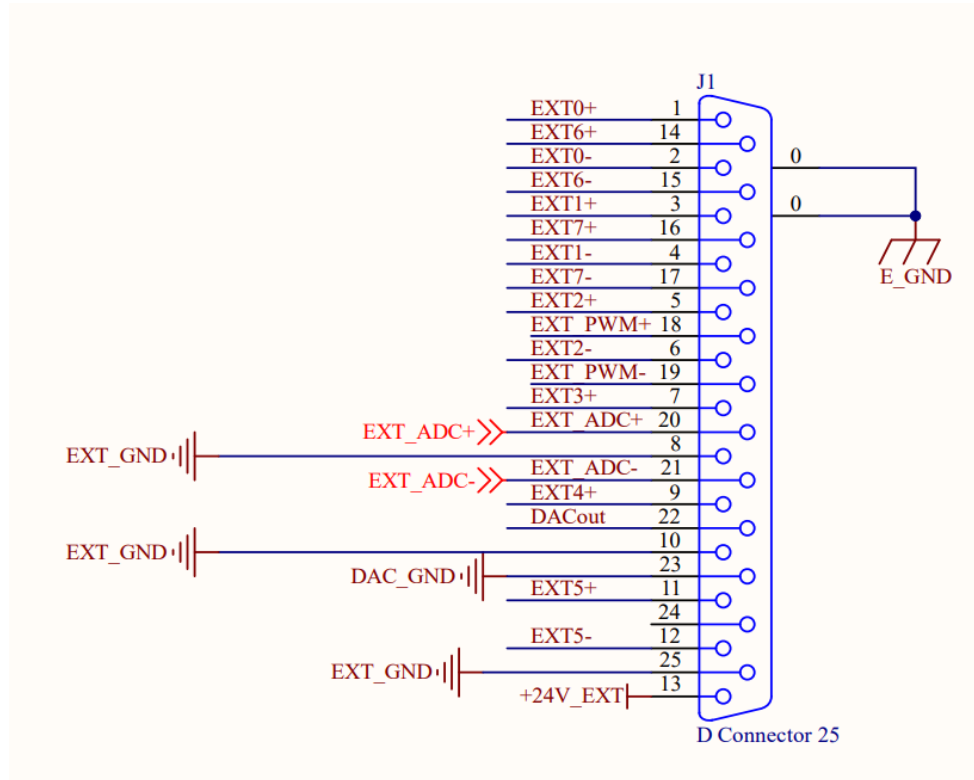

Pin NO.	Definition	Remarks
1 (EN+)	Remote control light, front panel red indicator light up. Emission enable	(5-24V)
2 (EN-)	GND	(0V)
18 (PWM+)	Modulated signal input	(5-24V)
19 (PWM-)	Return	(0V)
20 (DA+)	Analog input to control current	(0-10V)
21 (DA-)	GND	(0-10V)

Note: please check the level of the control signal to ensure compliance. Voltage excess or voltage fluctuation may damage the laser. Ensure that the analog voltage signal does not exceed 10V, otherwise the laser may be damaged.

Control signal line

All the control signals of the laser are concentrated on the control signal (DB25 interface) port of the rear panel. The diagram on the right shows the **control signal line** provided by our company.



CAUTION: please check the level of the control signal to make sure it meets the requirement. Voltage excess or voltage fluctuation may damage the laser.

LAN: laser LAN communication, can monitor the running state of the laser.

WATER: waterpipe interface, inlet and outlet are used for cooling water inflow and outflow. This interface is suitable for $\Phi 16$ hosepipe pagoda interface.

AC POWER: control the on-off of alternating current.



Power switch on rear panel

CDA (right picture): clean and dry air interface, access clean and dry air to prevent laser condensation..



CDA usage:

- 1) The CDA needs to be dried and cooled by a cold dryer, through 5um and 0.3um particle filters, and 0.1um oil mist filter, respectively. The temperature is in the range of 5-40°C, the highest dew point is 0°C (it is recommended that the compressed air temperature is 5°C lower than cooling water temperature), the air pressure is around 0.1mpa, the flow rate is set at 10LPM, and the interface pipe diameter is 6-12mm.
- 2) Ventilation shall be started 30min before the CDA starts. Ventilation can be stopped when the temperature is lower than 10°C and humidity is lower than 50% in winter.

4.4 Power connection

CAUTION: (1) before connecting to the AC power supply, please check that the laser model is consistent with the AC power supply below. (2) The wrong connection will cause damage to the laser, so please check that the power cord connection is correct before the laser is powered on.

Power outlet

The other end of the power supply is a stripped four-strand wire, which marks as, L1, L2, N and PE. It can be connected to two groups 220V AC power supply according to the wire mark. The power cord must be reliably connected as shown in the table before the laser is powered on.

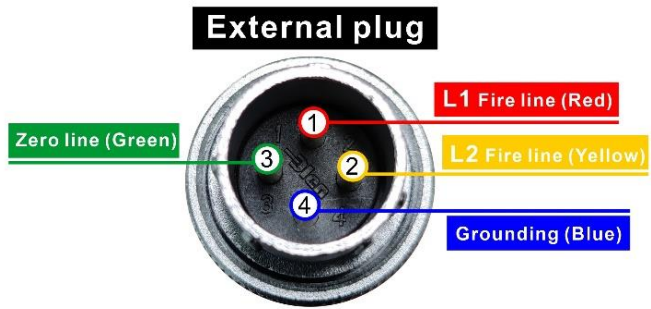

Makes	Color	Definition
L1	Red	Fireline
L2	Yellow	Fireline
N	Green	Zero line
PE	Blue	Grounding

power-line connection

Depending on the power of the laser, below 2KW: using 220V single-phase three-wire power cords, circuit breakers with a rated working current $\geq 60A$; 2KW-3KW: using 4-core wires, 380V three-phase four-wire, circuit breaker with rated working current $\geq 100A$.

All circuit breakers used must have zero line and be effectively grounded.

The power cord must be connected when the power is off.

Take out the power cord in the packing box, insert one end into the AC power interface of the laser, and connect the other end of the power cord to the correct hole according to the mark on the line (as shown in the figure)



The **power cord** provided by our company:

Insert the plug at the end of the power supply into the AC power interface on the rear panel. Note that the plug has an anti-reverse connection function.

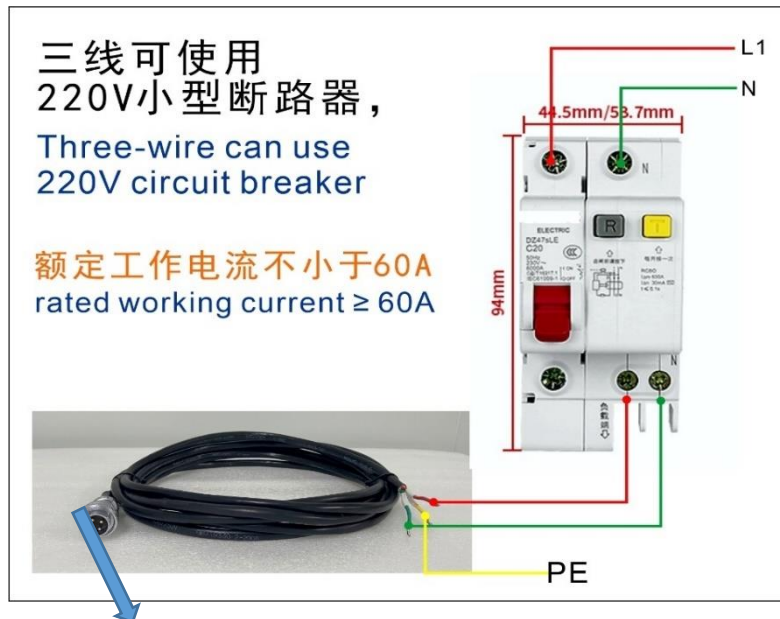

CAUTION: please check the level of the control signal to make sure it meets the requirement. Voltage excess or voltage fluctuation may damage the laser.

4.5 Start operating procedures

Make sure that the air switch on the rear panel of the laser is disconnected and that the "EMERGENCY STOP" button on the front panel has been pressed. All electrical connections must be completed before the laser is powered on.

- 1) Turn on the chiller to ensure that there is no leakage throughout the waterway. The chiller starts working and the water temperature is at the appropriate working temperature (**refer to 3.8 Precautions for the cooling system**).
- 2) Release the "emergency stop" switch on the front panel of the machine, and then turn the **power switch** on the rear panel to "ON".
- 3) Turn on the laser power supply and all the indicator lights on the panel are off (DB15 PIN7 input 0V). The laser enters the on-going state.

4.6 Control Mode Selection

4.6.1 External control mode (daily use status)

- 1) Turn the key switch to "ON".
- 2) Wait for the completion of the laser self-test (about 10s), the front panel "POWER" indicator light is always on. The laser is turned on by an external controller connected by the DB15 signal line (PIN7 provides 24V voltage to enable the laser output).

4.6.2 Internal control mode (for debugging only)

- 1) Turn the key switch to "REM".
- 2) Wait for the internal main control board circuit initialization completed (about 10 S), and the front panel "POWER" indicator light will be on.
- 3) Connect the laser with the computer with the RS232 serial port line, and control the laser through the computer control software.

Steps:

- 1) Please turn on the computer and insert the U disk, as shown in the figure: click the **PL2303** folder, double-click to install the driver.

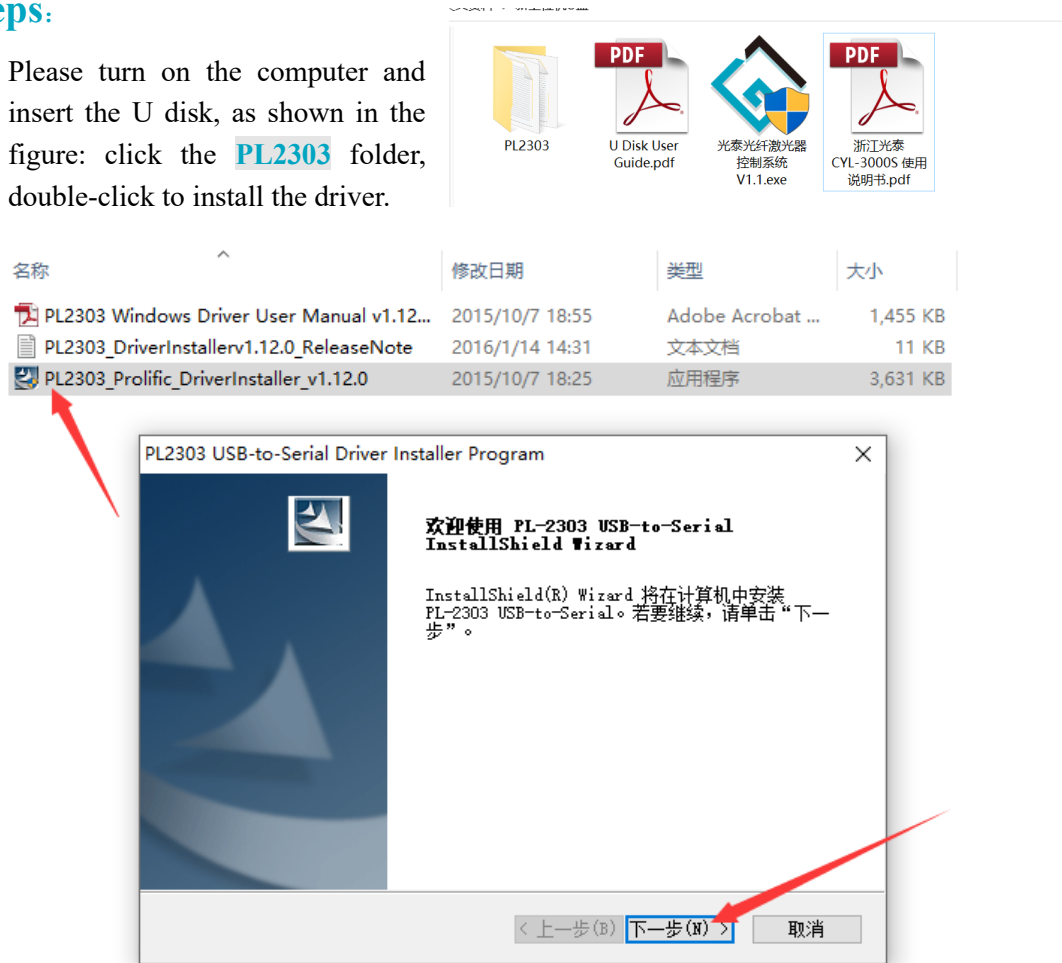

- ➡ One end of the RS232 line is connected to the **RS232 interface** on the rear panel of the laser, and one end is connected to the USB interface on the PC.

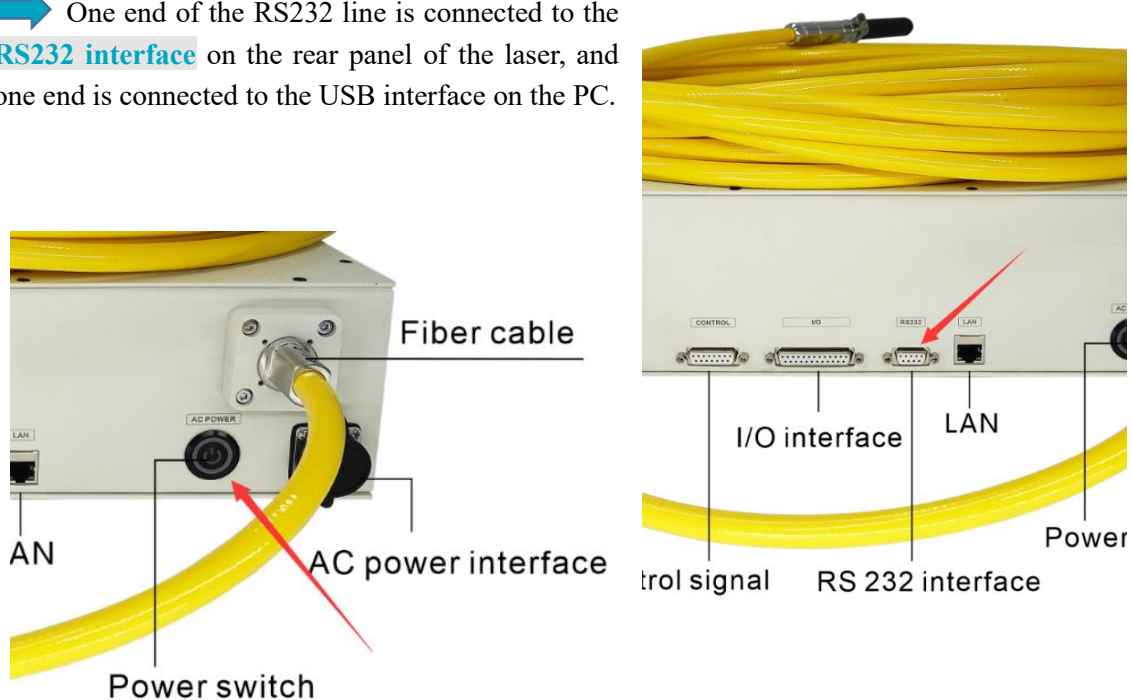

- ↑ When the laser is powered on, press the **Power switch** button on the rear panel, and the green light of the button is always on.

- 2) Double-click **GT Fiber Laser Control System V1.23** (laser control software).

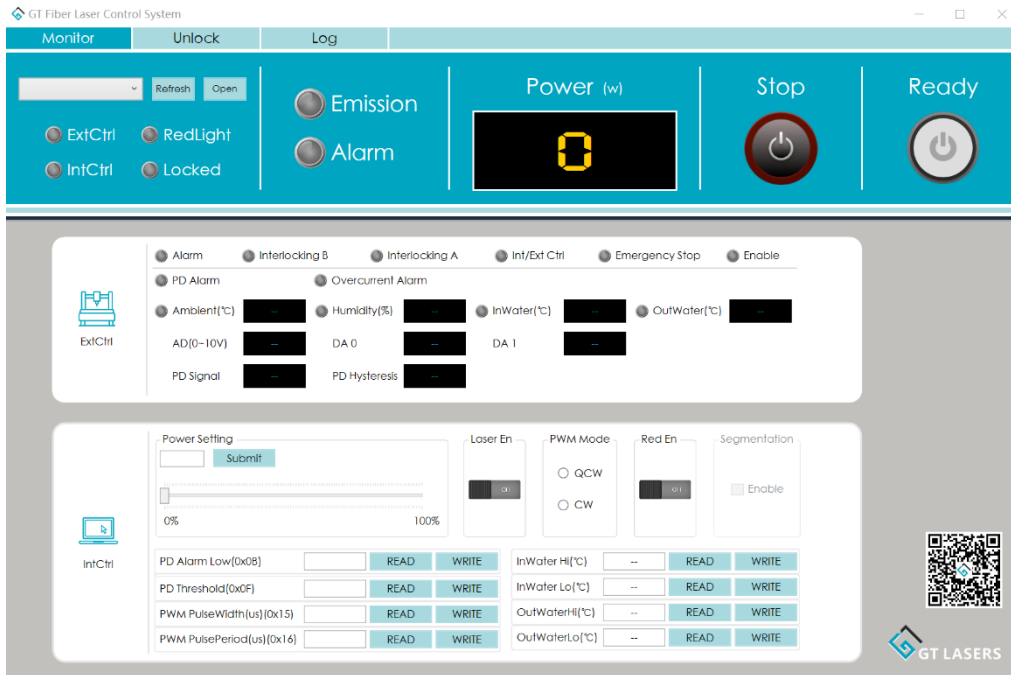

- 3) Click **Refresh** , select the corresponding port and connect.



- 4) **QCW mode:** the optical laser can produce pulse of μs magnitude, duty cycle is 10%. This allows the pulsed light to have a peak power of more than ten times the average power, which is very beneficial for applications such as drilling. The repetition frequency can be modulated up to 2KHz according to the pulse width.

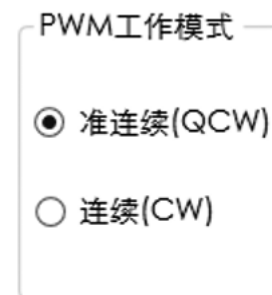

- 5) Select quasi-continuous **(QCW)** in **PWM working mode**.
- 6) The default (minimum) value of PWM quasi-continuous pulse width is **50 μs** , and the default (minimum) value of PWM quasi-continuous cycle is **500 μs** .

Customers can increase the value of quasi-continuous cycle according to the requirement, and increase the percentage of quasi-continuous pulse width to set the working frequency of the o



5.0 Quality Assurance and Repair and Return Process

5.1 General warranty

Unless otherwise specified, GT Lasers provides a 24-month warranty for all products for material defects and quality problems (from the date of shipment). GT Lasers will choose 1) repair 2) replace 3) refund products that are confirmed to be defective and still within the warranty period. All repaired or replaced products continue to use the initial warranty period of the original repair product, that is, free repairs can be submitted only during the remaining warranty period of the original repaired product. The buyer must submit written repairs within 30 days after finding any quality problems. All repair requests must be submitted directly by the buyer, GT Lasers will not accept any third party repair requirements.

The above repair is not applicable to product problems caused by the following situations:

- 1) Incorrect or improper maintenance or calibration performed by non-GT Lasers personnel.
- 2) Software, interfaces or power supplies provided by customers or third parties.
- 3) Unauthorized maintenance or repair, incorrect operation beyond the limits of product parameters.
- 4) Abuse, negligence, accident, loss or damage during transportation;

The technical guidance and service provided by GT Lasers to customers will not affect the warranty terms provided by GT Lasers.

5.2 Services and maintenance

CAUTION: there are no built-in parts for user maintenance. All maintenance shall be carried out by GT Lasers personnel. Therefore, the maintenance or replacement requirements in the warranty scope must be notified to GT Lasers or the service representative as soon as possible. Approved returned products must be placed in suitable containers.

If the goods are found to be damaged, it shall be reported to the carrier in writing in time.

IMPORTANT: please do not return the product to GT Lasers without a Return Merchandise Authorization (RMA). If the warranty period of the product has expired, or the product is not within the scope of maintenance, the buyer will bear the maintenance costs.

IMPORTANT: users should keep the software log files properly for the convenience of the GT Lasers maintenance personnel for fault analysis.

5.3 Change

We reserve the right to change the design and structure of the products, and we will not be responsible for any modification of the same model products that have been sold.